



FUEL CLOUD



**Small Business
Pedestal**

Installation Manual

Manual Version 1.2
Revised 8/19/24



Welcome to FuelCloud!

This installation guide contains all of the information you need to install your Small Business Pedestal.

Before beginning physical installation of a Small Business Pedestal, create an account at [FuelCloud.com](https://fuelcloud.com) and register the iPad's serial number at its install site. Installation cannot be completed unless iPads are registered online.



Table of Contents

Privacy Statement / FCC Statements / Terms and Conditions	3
Compatibility & Specs	4
Parts List	6

Before Installation

Hardware and Install Warnings	7
Identify Your Installation Location	10
Turn Power Off	11
Mount	11

Installation

Enclosure Mounting	13
Power Wiring	15
Optional CloudBox/CloudLink Installation	20
Internet Configuration	21



Privacy Statement

FuelCloud is committed to protecting user's privacy. For more information about FuelCloud's privacy policy, please review our full terms and conditions at: fuelcloud.com/privacy-policy



FCC Statements

Find complete details of our FCC compliance at:
fuelcloud.com/fcc-compliance



Terms and Conditions

For a complete terms and conditions, including warranty disclaimers visit: fuelcloud.com/terms-condition



Compatibility & Specs

Input Power Requirements	120VAC, 50/60Hz
Dimensions	Height: 67.23" (170.76cm) Width: 19.12" (48.56cm) Depth: 9.12" (23.16cm)
Weather Ratings	NEMA 3R, 3Rx / IP24
Temperature Ratings	Adjustable heater & fan. Preset at: <ul style="list-style-type: none">• Heater on at 45F (7C)• Fan on at 80F (26C)
I/O	Wi-Fi Ethernet (optional)

Declaration of Conformity:

Hereby, FuelCloud, declares that this Small Business Pedestal is in compliance with the essential requirements and other relevant provisions of Directive 2014/53/EU. The full text of the EU declaration of conformity is available at the following internet address: [URL of DoC]

FuelCloud vakuuttaa täten että Small Business Pedestal tyyppinen laite on direktiivin 2014/53/EU oleellisten vaatimusten ja sitä koskevien direktiivin muiden ehtojen mukainen. The full text of the EU declaration of conformity is available at the following internet address: [URL of DoC]

Hierbij verklaart FuelCloud dat het toestel Small Business Pedestal in overeenstemming is met de essentiële eisen en de andere relevante bepalingen van richtlijn 2014/53/EU. The full text of the EU declaration of conformity is available at the following internet address: [URL of DoC]

Bij deze verklaart FuelCloud dat deze Small Business Pedestal voldoet aan de essentiële eisen en aan de overige relevante bepalingen van Richtlijn 2014/53/EU. The full text of the EU declaration of conformity is available at the following internet address: [URL of DoC]

Par la présente FuelCloud déclare que l'appareil Small Business Pedestal est conforme aux exigences essentielles et aux autres dispositions pertinentes de la directive 2014/53/EU. The full text of the EU declaration of conformity is available at the following internet address: [URL of DoC]

Par la présente, FuelCloud déclare que ce Small Business Pedestal est conforme aux exigences essentielles et aux autres dispositions de la directive 2014/53/EU qui lui sont applicables. The full text of the EU declaration of conformity is available at the following internet address: [URL of DoC]

Hiermit erklärt FuelCloud, dass sich dieser/diese/dieses Small Business Pedestal in Übereinstimmung mit den grundlegenden Anforderungen und den anderen relevanten Vorschriften der Richtlinie 2014/53/EU befindet". (BMW) The full text of the EU declaration of conformity is available at the following internet address: [URL of DoC]

ΜΕ ΤΗΝ ΠΑΡΟΥΣΑ FuelCloud ΔΗΛΩΝΕΙ ΟΤΙ Small Business Pedestal ΣΥΜΜΟΡΦΩΝΕΤΑΙ ΠΡΟΣ ΤΙΣ ΟΥΣΙΩΔΕΙΣ ΑΠΑΙΤΗΣΕΙΣ ΚΑΙ ΤΙΣ ΛΟΙΠΕΣ ΣΧΕΤΙΚΕΣ ΔΙΑΤΑΞΕΙΣ ΤΗΣ ΟΔΗΓΙΑΣ 2014/53/EU. The full text of the EU declaration of conformity is available at the following internet address: [URL of DoC]

Con la presente FuelCloud dichiara che questo Small Business Pedestal è conforme ai requisiti essenziali ed alle altre disposizioni pertinenti stabilite dalla direttiva 2014/53/EU. The full text of the EU declaration of conformity is available at the following internet address: [URL of DoC]

Por medio de la presente FuelCloud declara que el Small Business Pedestal cumple con los requisitos esenciales y cualesquiera otras disposiciones aplicables o exigibles de la Directiva 2014/53/EU. The full text of the EU declaration of conformity is available at the following internet address: [URL of DoC]

FuelCloud declara que este Small Business Pedestal está conforme com os requisitos essenciais e outras disposições da Directiva 2014/53/EU. The full text of the EU declaration of conformity is available at the following internet address: [URL of DoC]



Parts List

iPad Enclosure Mounting:

Quantity	Description
4x	5/16-18 X 1-1/4 HEX HEAD SCREW, SST
8x	5/16 FLAT WASHER, SST
4x	5/16 HEX NUT, SST
4x	5/16 SPLIT LOCK WASHER, SST

Top Mounting:

Quantity	Description
4x	1/4-20 HEX HEAD KEPNUT, SST
8x	1/4 FLAT WASHER, SST
4x	1/4-20 X 3/4 HEX HEAD SCREW, SST



BEFORE INSTALLATION

Hardware and Install Warnings

Installations must be in accordance with the National Electrical Code (NFPA No. 70) and the Automotive and Marine Service Station Code (NFPA No. 30A). The installer is responsible for investigating and following any applicable local codes.

Restricted Access:

Access can only be gained by service persons or by users who have been instructed about the reasons for the restrictions applied to the location and about any precautions that shall be taken.

Access is through the use of a tool or lock and key, or other means of security, and is controlled by the authority responsible for the location.

Seal offs must be used when conduit is exiting an explosion proof zone. (class 1 div 1 or class 1 div 2)

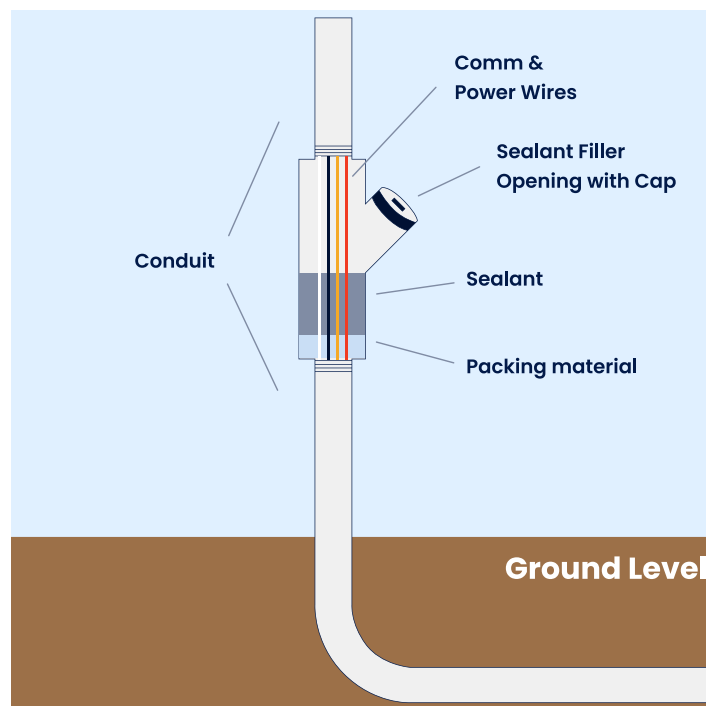

Hazardous Area (Where not to mount the CloudBox):

Do not mount the CloudBox or any FuelCloud device within the hazardous / classified area.

Hazardous Zones:

Dispensing Device	Class 1 Div 1	Class 1 Div 2
Compressed natural gas (CNG)	Entire space within the dispenser enclosure.	1.5 m (5 ft) in all directions from the dispenser enclosure.
Liquefied natural gas (LGN)	Entire space within the dispenser enclosure.	3 m (10 ft) in all directions from the dispenser enclosure.
Liquefied petroleum gas (LP-Gas)	Entire space within the dispenser enclosure; 450 mm (18 in.) from the exterior surface of the dispenser enclosure to an elevation of 1.22 m (4 ft) above the base of the dispenser; the entire pit or open space beneath the dispenser and within 6 m (20 ft) horizontally from any edge of the dispenser when the pit or trench is not mechanically ventilated.	Up to 450 mm (18 in.) above ground and within 6 m (20 ft) horizontally from any edge of the dispenser enclosure, including pits or trenches within this area when provided with adequate mechanical ventilation.

*Pulled from NEC 2018

Hazardous Area Examples:

Classified areas adjacent to dispenser mounted on aboveground storage tank:

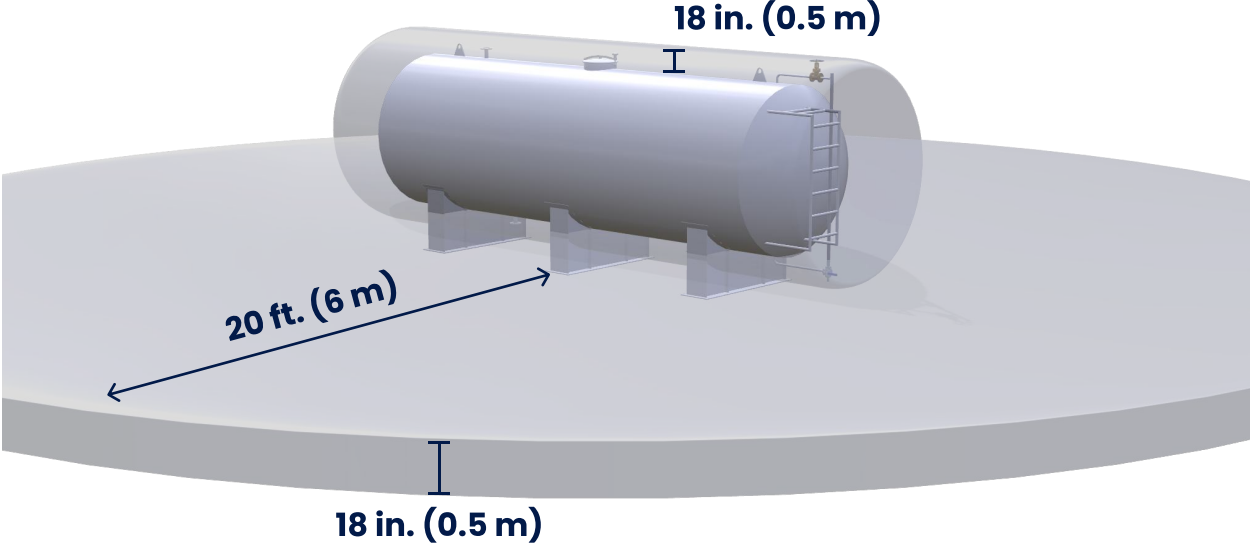

Classified areas adjacent to dispensers:

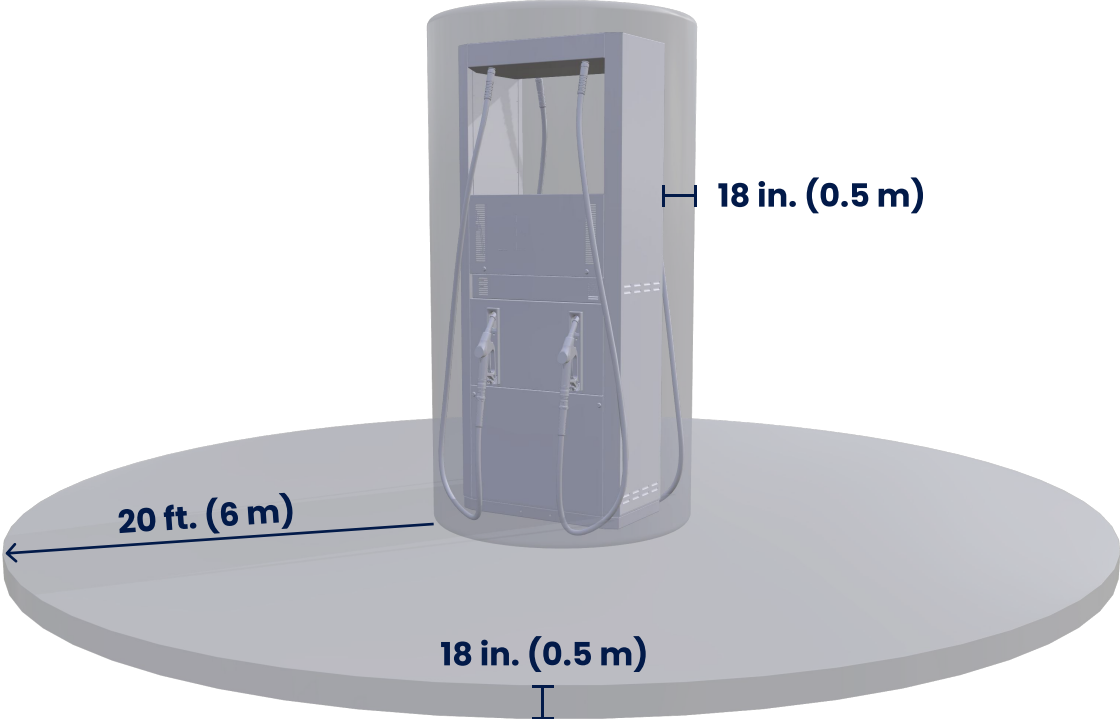



BEFORE INSTALLATION

Identify Your Installation Location

The Small Business Pedestal must be installed 18 inches away from all fuel dispensers and tanks. All conduits coming from hazardous areas must have seal-offs 18 inches above the hazardous zone. AC power is required. Choose a location where it is accessible.



Prevent glare by installing the pedestal facing north or south.

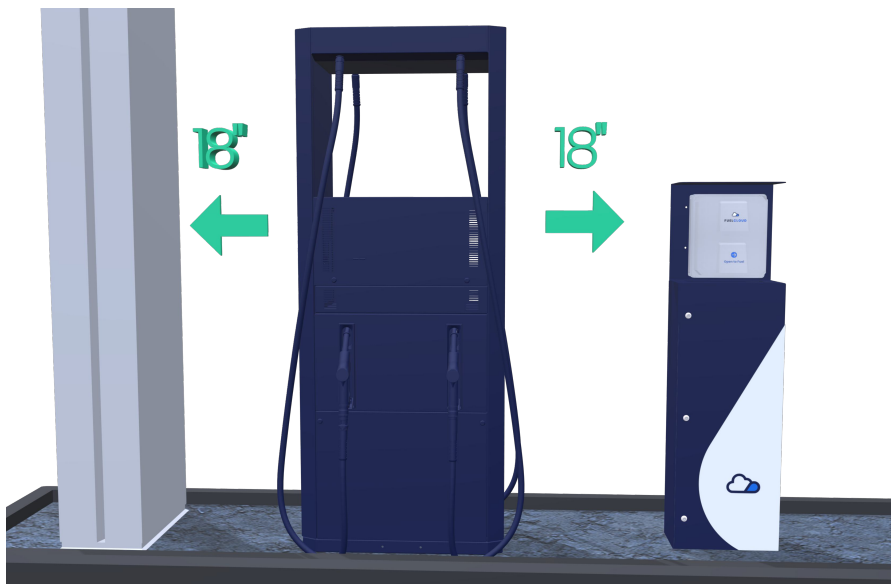

The base of the pedestal is 9.12" x 19.12":

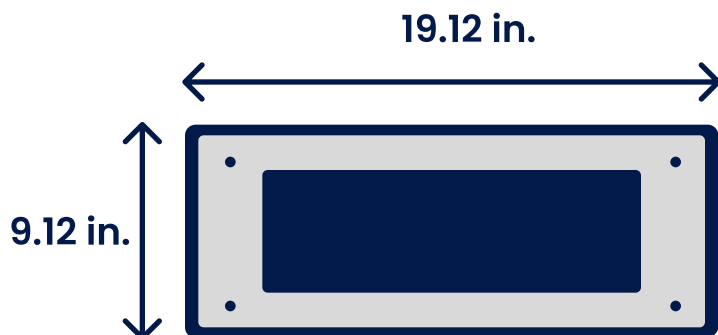



BEFORE INSTALLATION

Turn Power Off

Turn off all power to the pump at the breaker.



BEFORE INSTALLATION

Mount

Unlock and open the bottom panel of the pedestal:





BEFORE INSTALLATION

Mount

Bolt the pedestal into the ground:

Mark and drill 4 holes for cement anchor bolts. The mounting holes are 0.269".



Pedestal mounting plate dimensions (in):

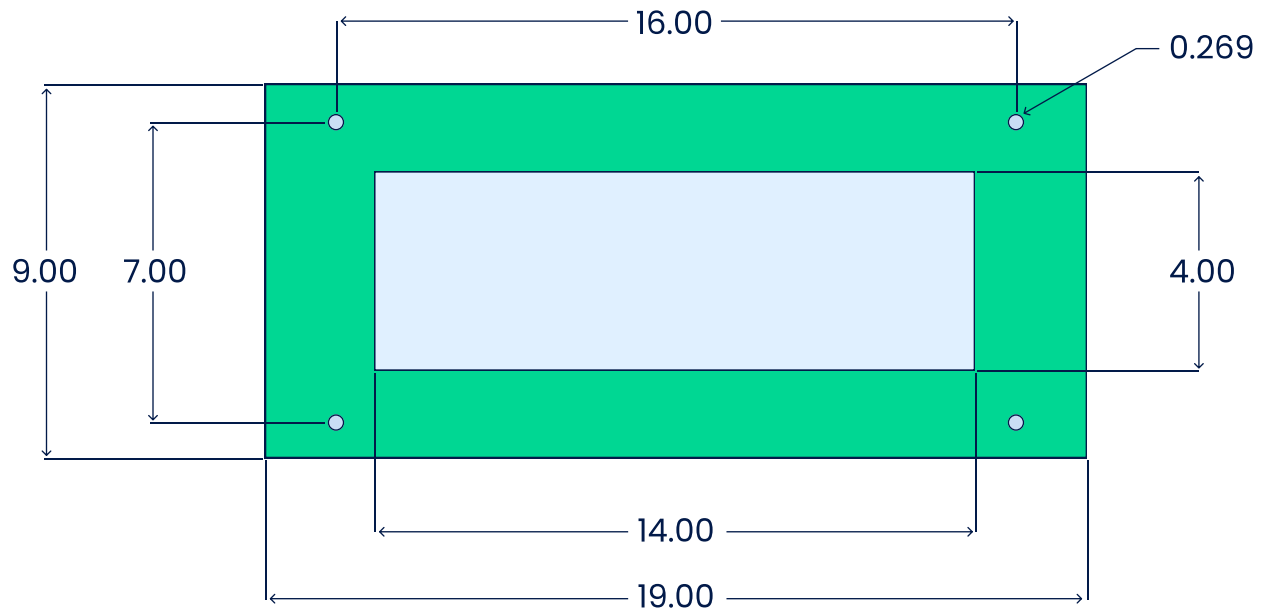



INSTALLATION

Enclosure Mounting

- 1 Mount the hood to the top of the pedestal with the 4 included nuts and bolts.

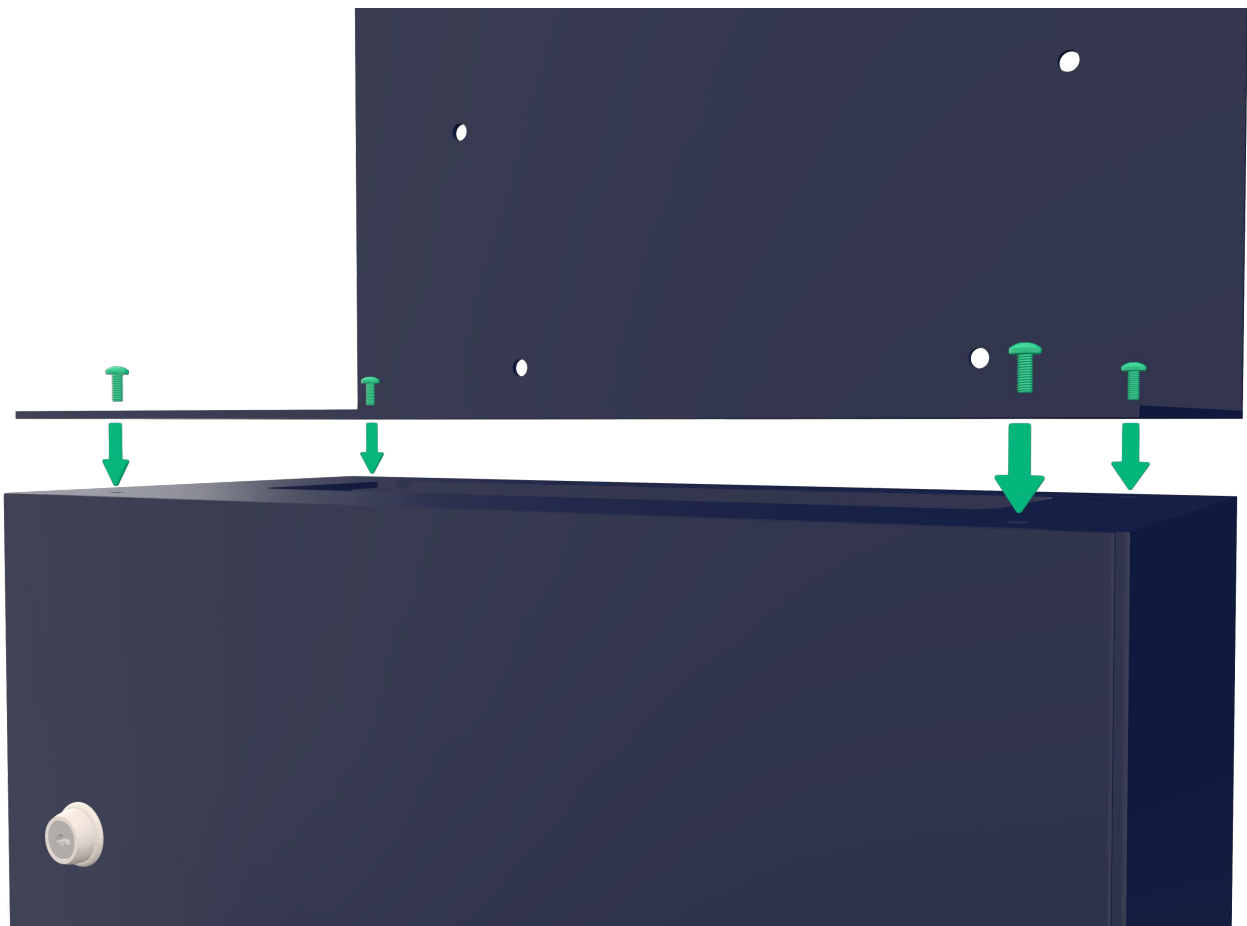



INSTALLATION

Enclosure Mounting

- 2 Mount the iPad enclosure onto the backing plate with the 4 included nuts and bolts.

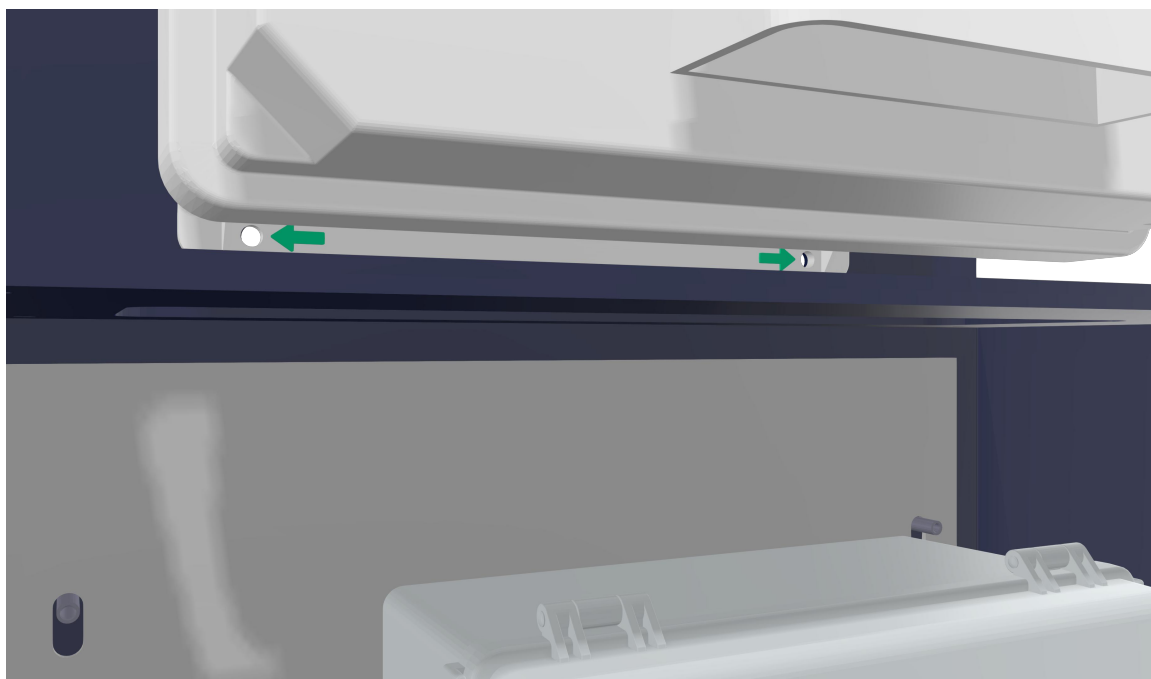



INSTALLATION

Power Wiring

- 1 Remove the 4 bolts holding the iPad plate inside the enclosure.

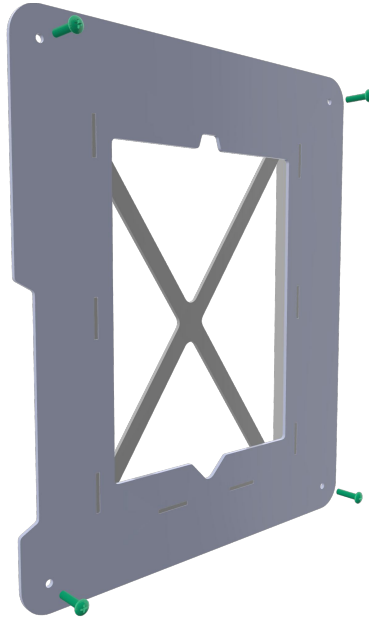

- 2 Connect Hot, Neutral, and Ground from the power supply to the iPad enclosure.

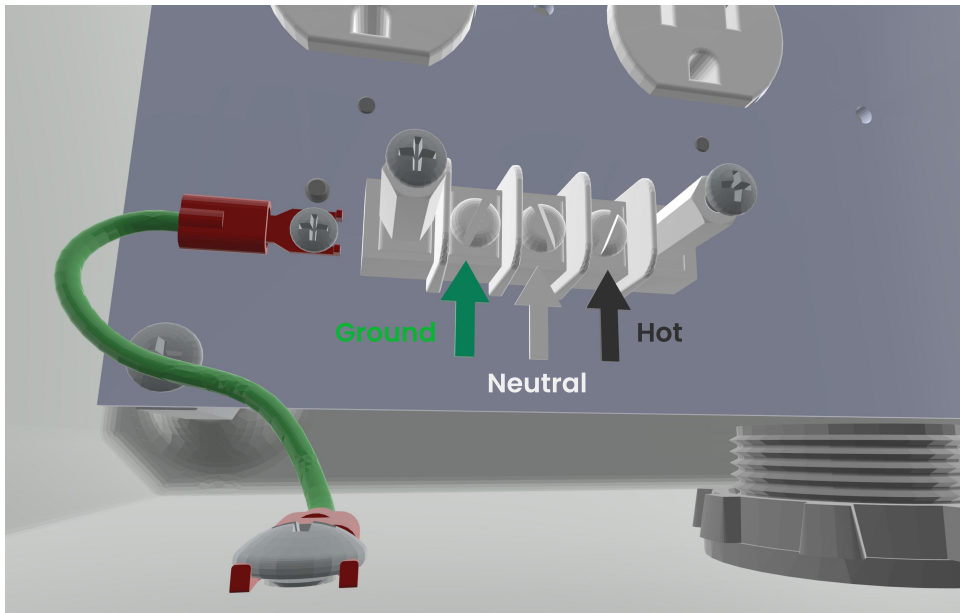



INSTALLATION

Power Wiring

- 3 Ensure that the fan thermostat (blue) is set to 80F and the heater thermostat (red) is set to 45F. These control temperatures can be adjusted based on climate.

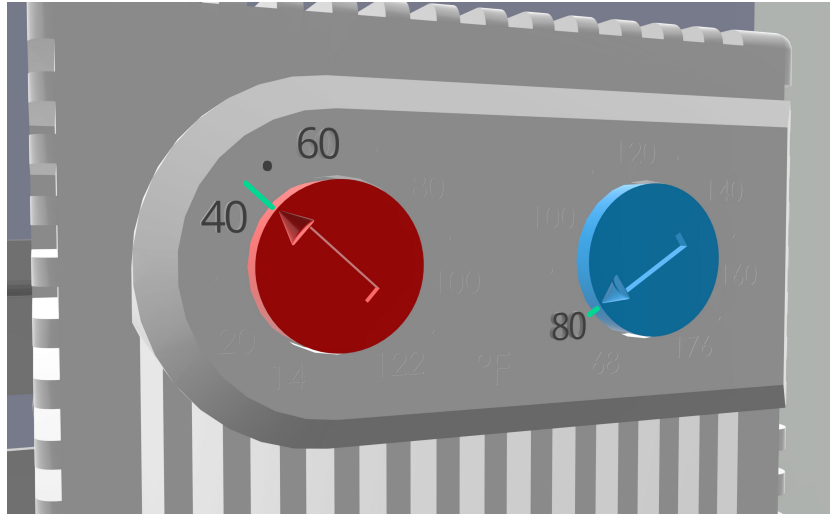

- 4 Slide the iPad (with case) into the iPad plate.

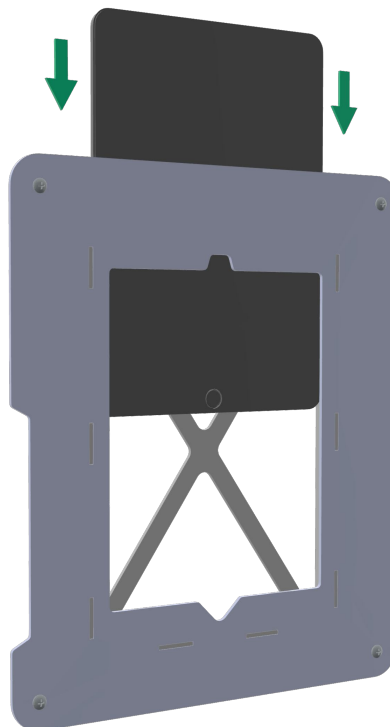



INSTALLATION

Power Wiring

- 5 Plug the ethernet adapter power cable into one of the 4 outlets inside the enclosure.

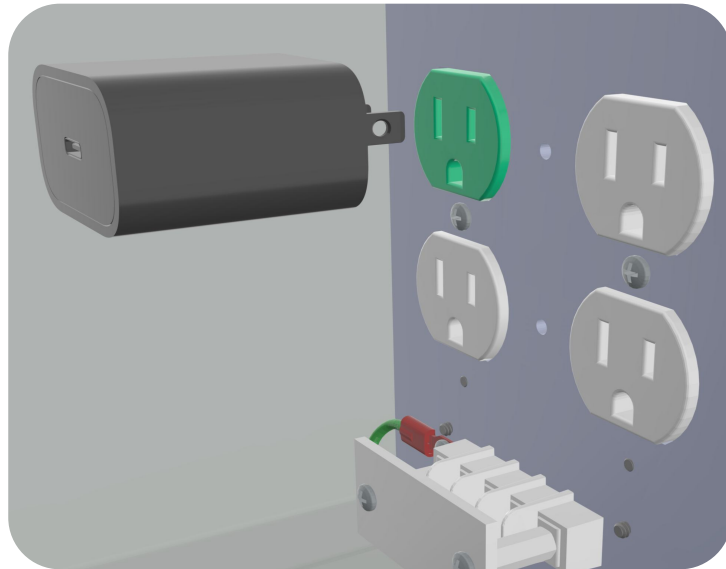

- 6 Connect the USB-C cable from the iPad power adapter to the ethernet adapter.

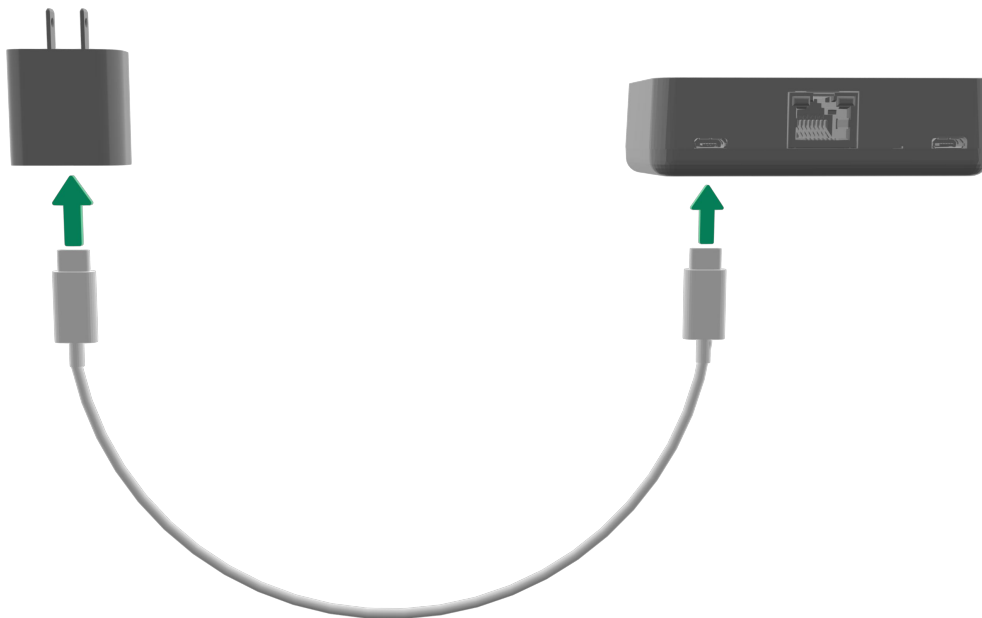



INSTALLATION

Power Wiring

- 7 Connect the USB-C cable from the ethernet adapter to the iPad.

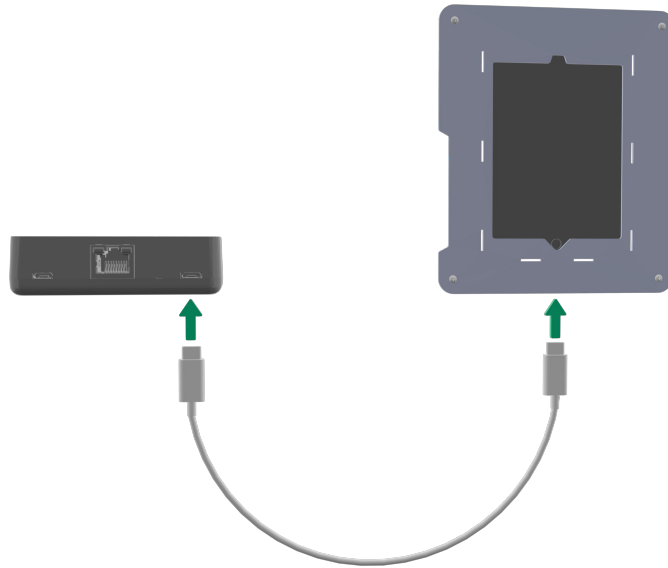

- 8 Connect an ethernet cable from the ethernet adapter to the CloudBox or to a router/switch.





INSTALLATION

Power Wiring

- 9 Reattach the iPad plate with the original 4 bolts.

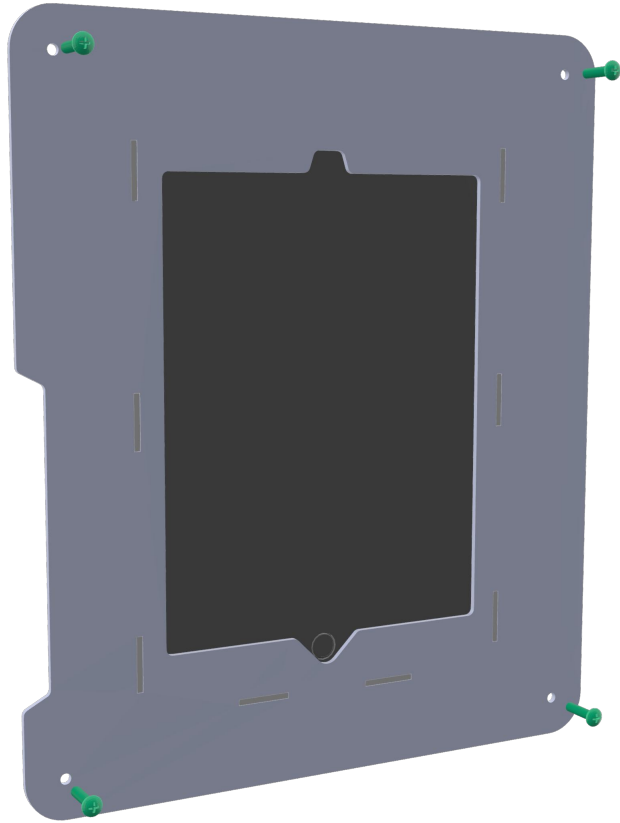



INSTALLATION

Optional CloudBox/CloudLink Installation

Install a CloudBox and/or CloudLink:

- 1 Remove the metal plate in the lower cabinet.
- 2 The **CloudBox** mounts with 4 bolts to the **top section** of the mounting plate shown below.
- 3 The **CloudLink** mounts with 4 bolts to the **bottom section** of the mounting plate shown below.
- 4 Reattach the mounting plate into the lower cabinet of the pedestal.

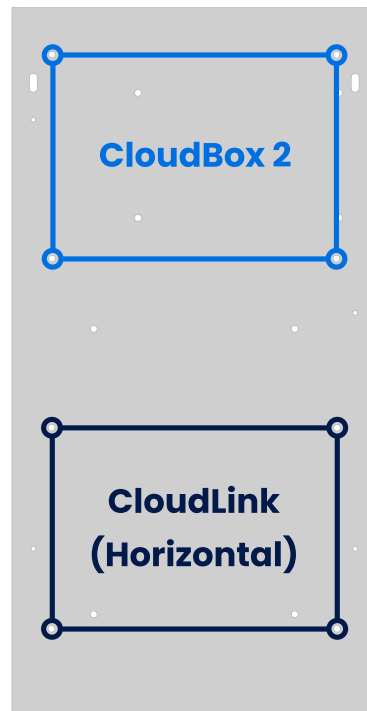
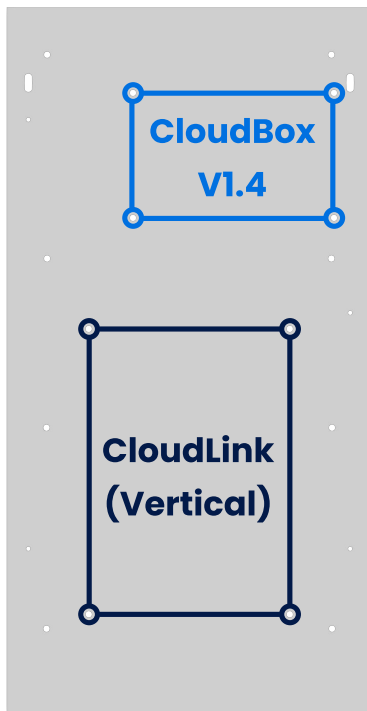

Note: Please refer to the CloudBox and CloudLink installation guides for power and pump wiring. CloudBox & CloudLink mounting hardware included with CloudBox/CloudLink.



INSTALLATION

Internet Configuration

Cellular:

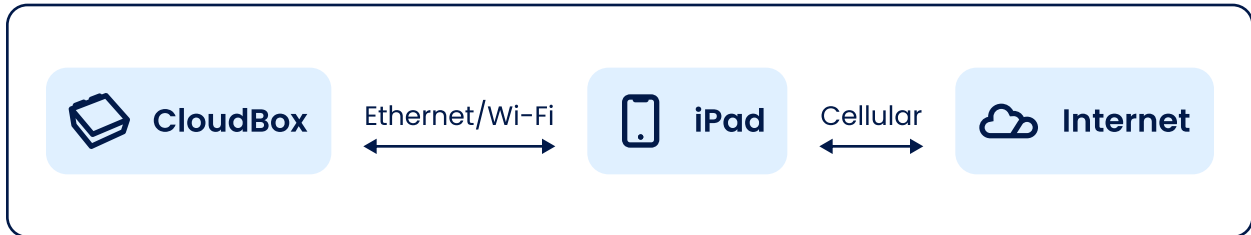

The iPad can communicate with the internet through cellular. The iPad will then communicate with the CloudBox over Wi-Fi or ethernet. **FuelCloud recommends connecting the iPad directly to the CloudBox with the included ethernet cable.**

Company Ethernet:

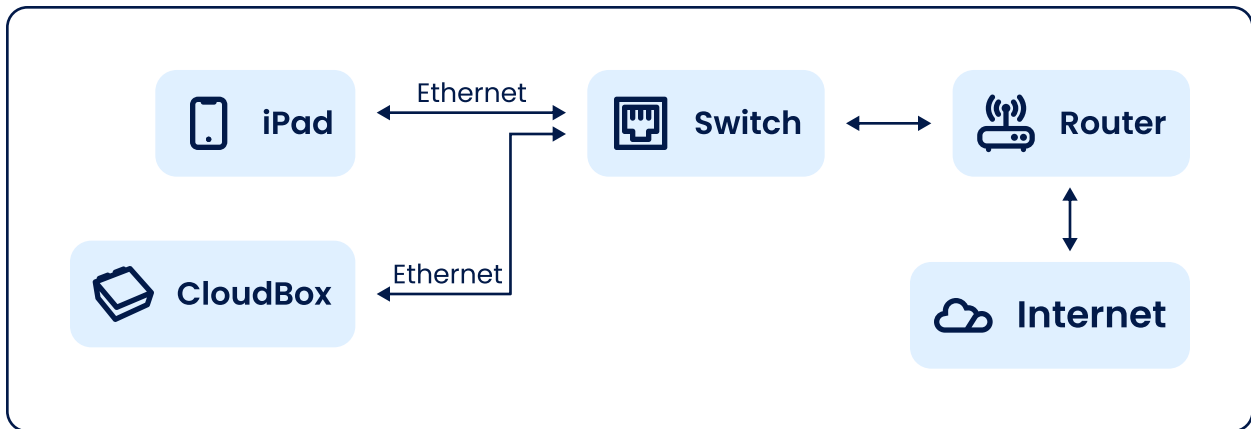

Connect the iPad, CloudBox, and router to an ethernet switch. If you did not purchase an optional ethernet switch, connect both directly to the router.



Note: For ethernet with a switch, the CloudBox will need to be on “client” mode.

Wi-Fi:

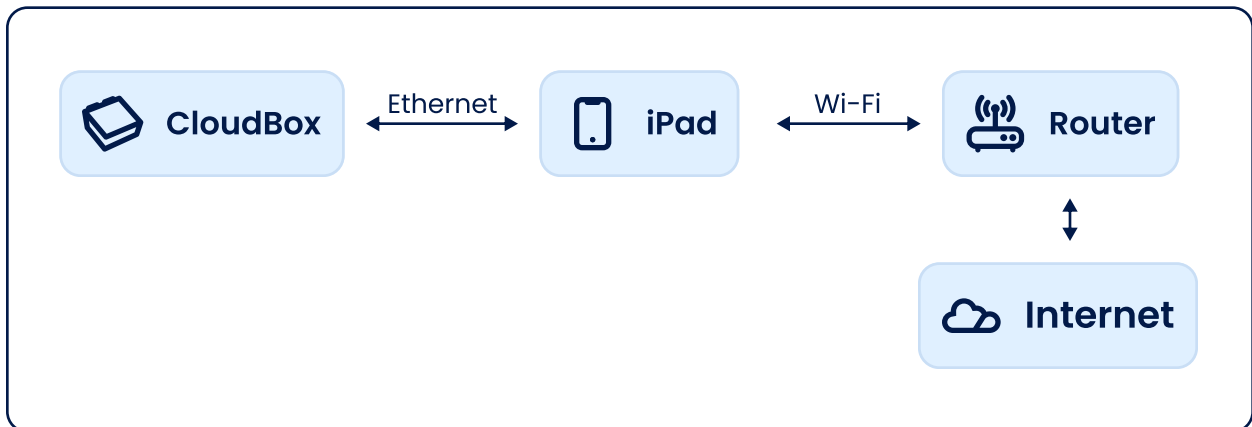

If cellular and hardwired ethernet are not options for connecting the iPad to the internet, the iPad can be connected to a Wi-Fi network. You will need to enter both the SSID and the password to bring the iPad online. The CloudBox can be connected directly to the iPad through ethernet.

Alternatively, the CloudBox can be connected to the same SSID:

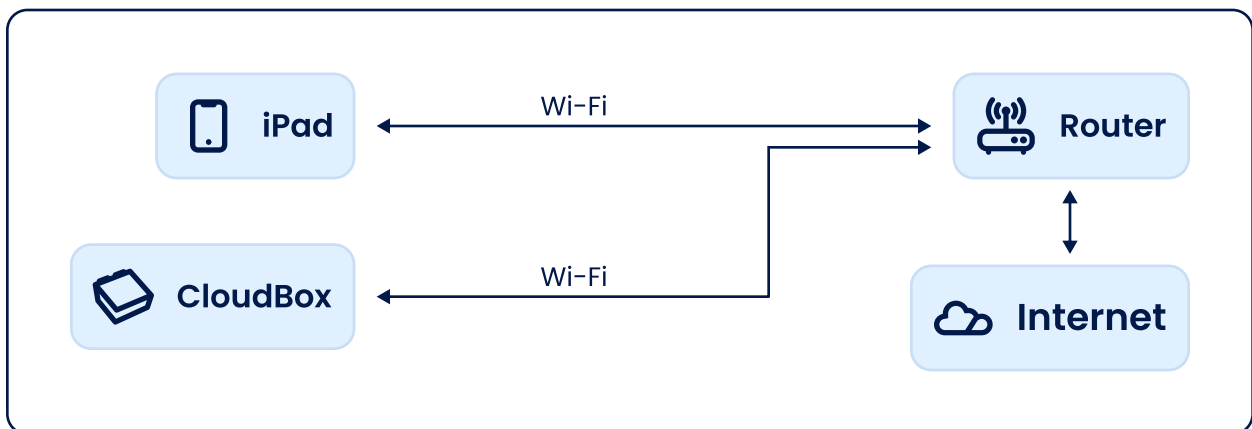



Revised 8/19/24

FuelCloud, Inc.
124 SW Dennis Ave
Hillsboro, OR 97123